

PARTS LIST			
ITEM	QTY	PART NUMBER	DESCRIPTION
1	8	M3x8mm Pan Screw	Rear/Front Panel Screws
2	8	M4x16mm CSK Screw	Bezel Screws
3	6	M3x6mm CSK Screw	Base Panel Screws
4	8	M6420000	Clip for Trims
6	2	M6401025	Front/Rear Bezel
7	1	M6403425	Rear Panel - 1.5 mm thick
8	2	M6400053	Front Trim
9	2	M6400073	Rear Trim
10	1	M6403031	LH Chassis Plate
12	1	M6403032	RH Chassis Plate
11	1	M6403120	Base Panel
13	1	M6402030	Wrap Around Cover
14	2	M6420206	Tilted Technofeet Kit

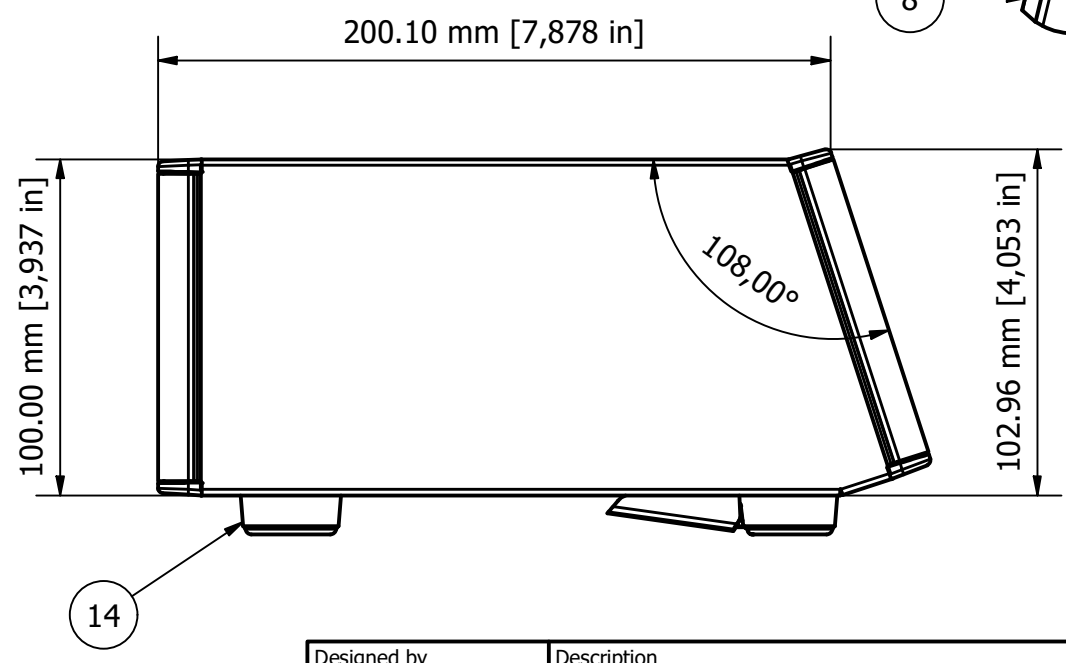
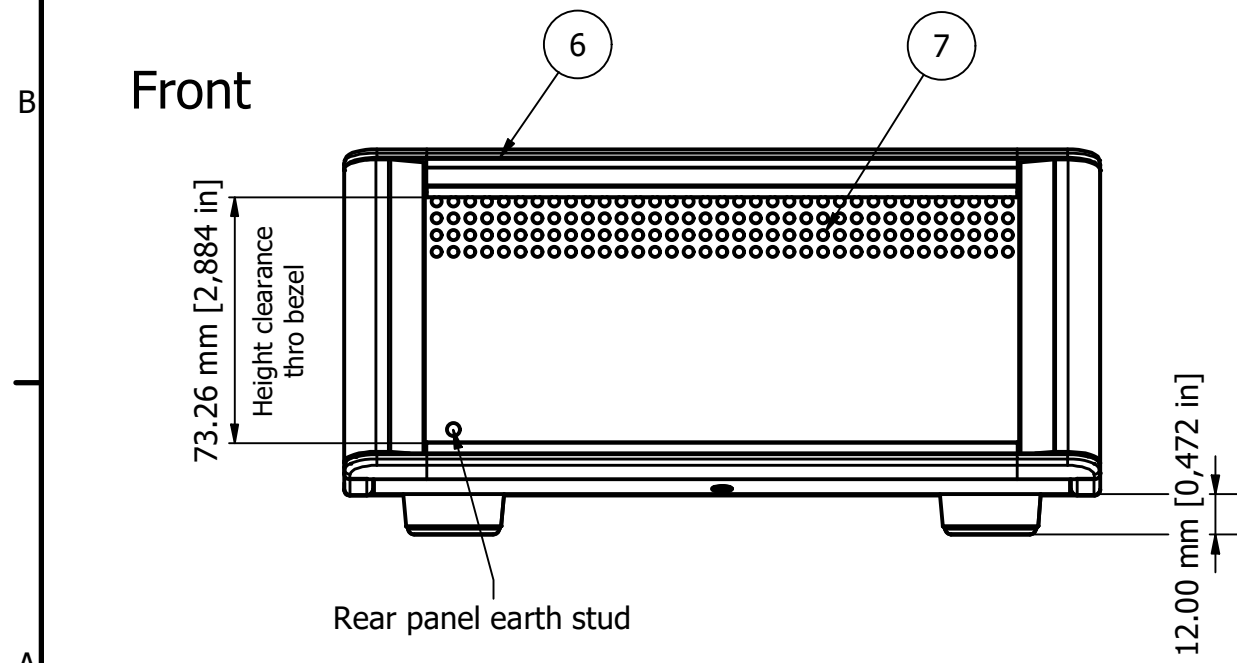
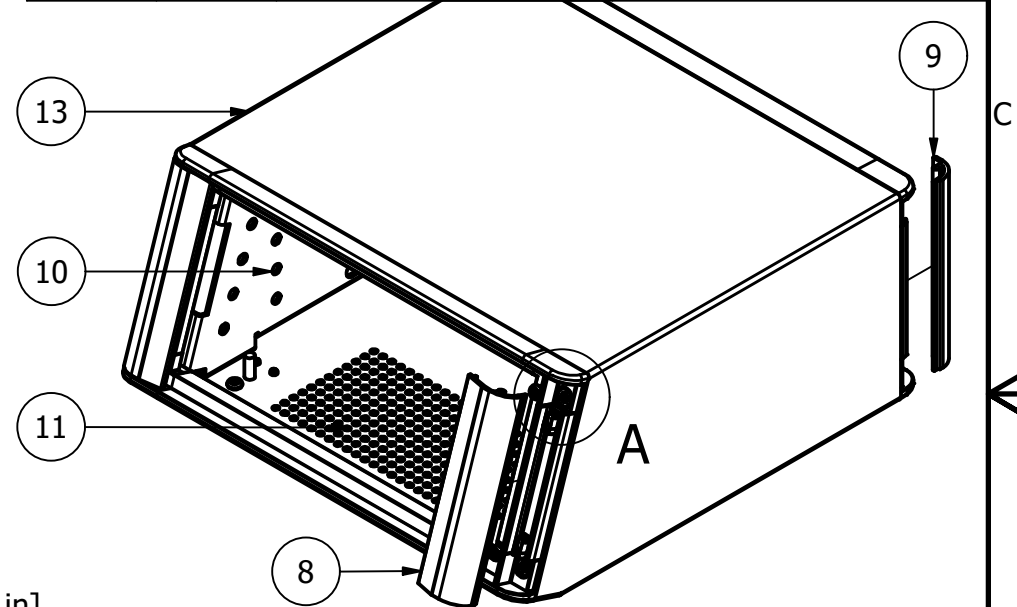

FIRST ANGLE PROJECTION

Front panel (M6400701) sold separately

© OKW Enclosures Ltd (Date as shown). This drawing contains proprietary information of OKW Enclosures Ltd and is tendered subject to the following conditions. The information be retained in confidence, not be reproduced or copied, and not be used or incorporated in any product, unless permission is obtained in writing from OKW Enclosures Ltd.

Designed by L Clark	Description Technomet SL110 - RAL 9016 & RAL 7042	Date 04/03/2025	Scale 1:2.25
<b>METCASE ENCLOSURES</b> 15 Brunel Way, Segensworth East, Fareham, Hampshire, PO15 5TX, UK. Tel: +44 (0)1489 583858 Email: sales@metcase.co.uk		<b>METcase™</b> www.metcase.com Part Number <b>M6423126</b>	
		Issue 1	Sheet 1 / 2

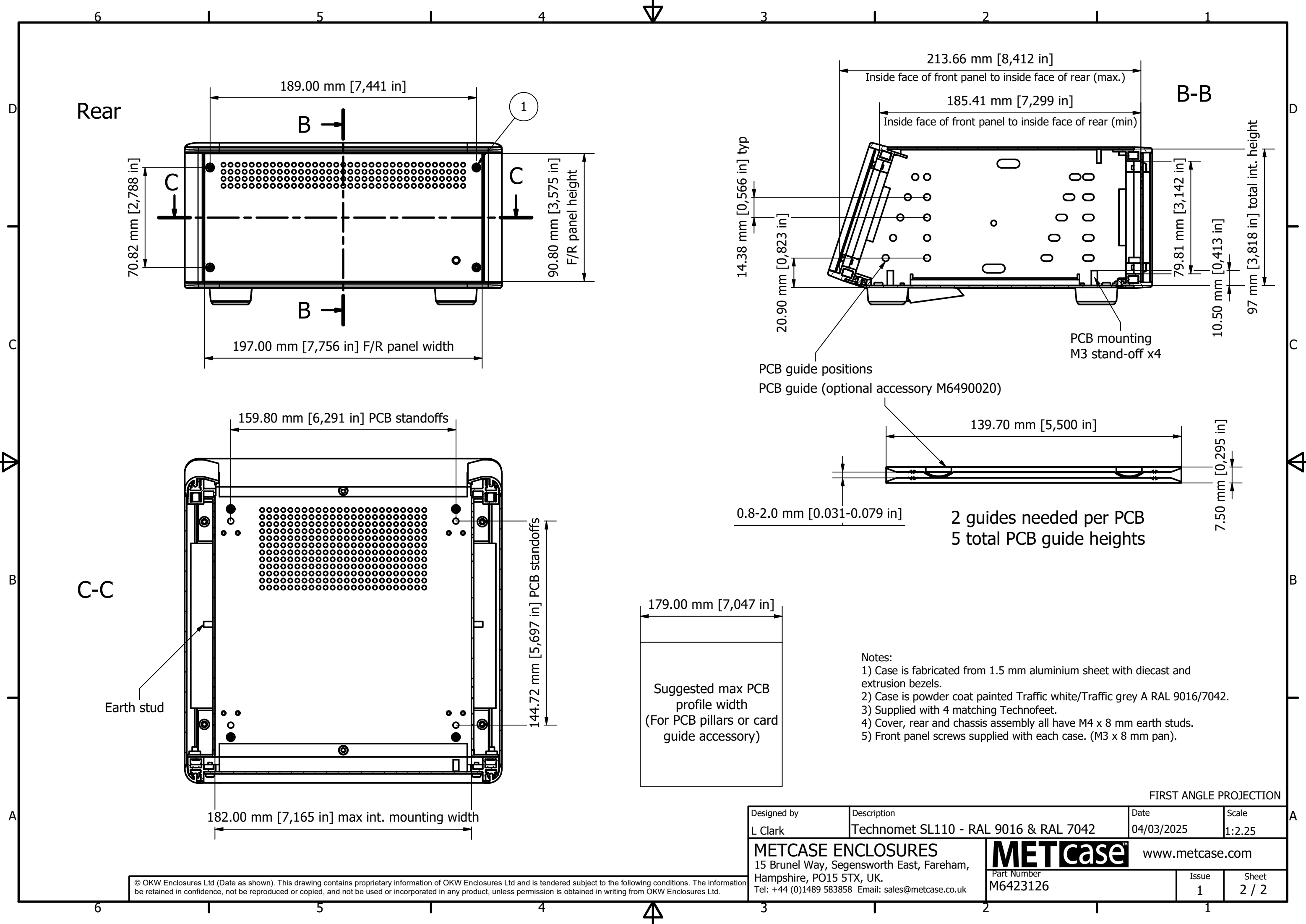

© OKW Enclosures Ltd (Date as shown). This drawing contains proprietary information of OKW Enclosures Ltd and is tendered subject to the following conditions. The information be retained in confidence, not be reproduced or copied, and not be used or incorporated in any product, unless permission is obtained in writing from OKW Enclosures Ltd.

Designed by L Clark	Description Technomet SL110 - RAL 9016 & RAL 7042	Date 04/03/2025	Scale 1:2.25
<b>METCASE ENCLOSURES</b> 15 Brunel Way, Segensworth East, Fareham, Hampshire, PO15 5TX, UK. Tel: +44 (0)1489 583858 Email: sales@metcase.co.uk		<b>METcase™</b> www.metcase.com Part Number <b>M6423126</b>	
		Issue 1	Sheet 2 / 2